

HMB
LINTECmarine

Windfarm Service Cranes

We are a proven supplier of lifting and mechanical handling equipment to the offshore, marine and wind industries which include Pedestal Cranes, Gantry Cranes and Winches that are particularly suitable for offshore wind farm substations.

We have added to its already impressive equipment catalogue with the development of its 2 Tonne Service Crane - aimed at the logistic and maintenance aspects of wind farm and turbine installations.

The crane's innovative compact design uses extra high grade steel - increasing strength yet reducing weight, while high quality equipment and low maintenance components make it an ideal solution for light lifting and handling operations on unmanned, low use applications.

Proteus 2 Tonne Service Cranes are simple, safe, reliable, low maintenance, operator friendly and can be easily configured to suit the specific requirements of an individual project or client.

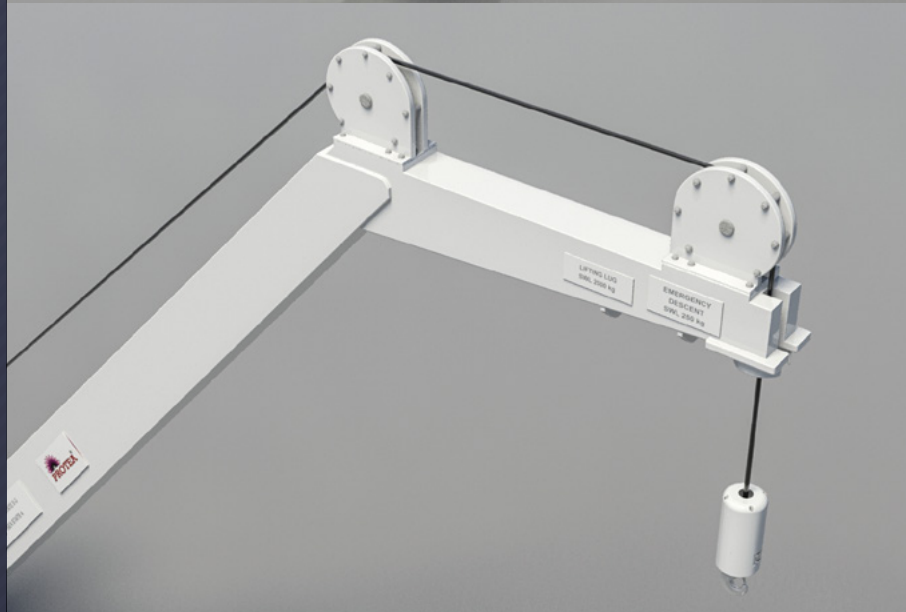
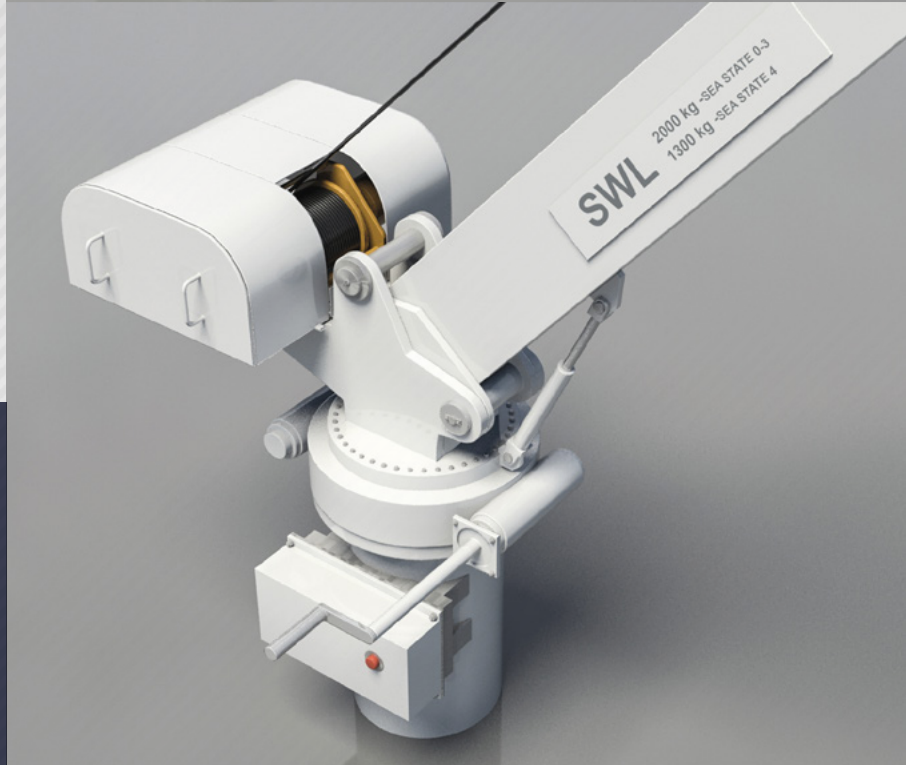
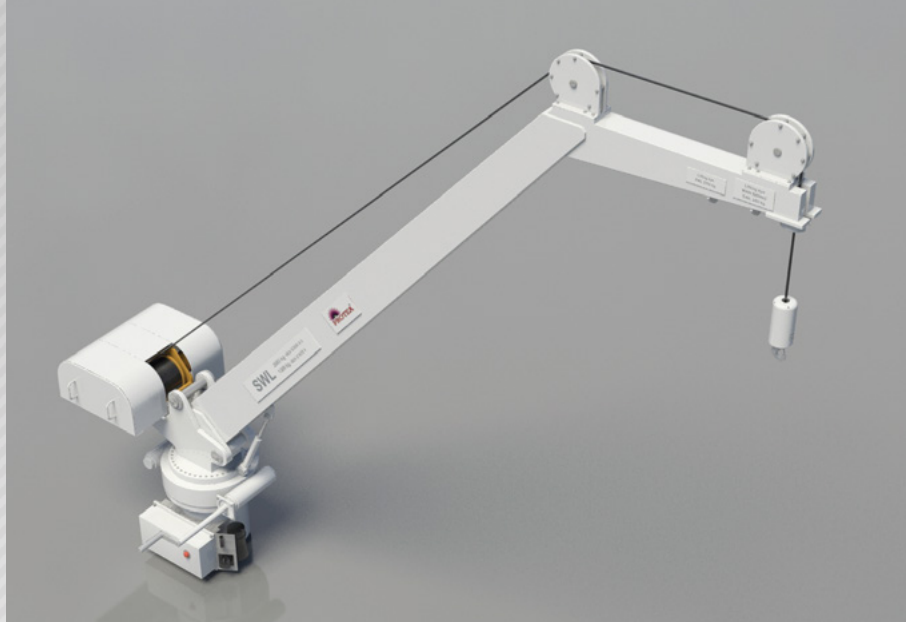

STANDARD PACKAGE INCLUDES:

- Designed in Accordance with DNV and NORSOK
- Fully Electric Hoist
- AOPS/MOPS Overload Protection
- Remote Operator Control
- Manual Slew Drive
- Pedestal Adapter

ADDITIONAL OPTIONS:

- Boom Lowering Service Tool
- Removable Davit for Winch Maintenance
- Bolted or Welded Pedestal Adaptors
- Electrical Slew Drive
- Frequency Inverter For Improved Winch Control
- Visual Display for Service Requirements